

# Rosemount™ 225

## Toroidal Conductivity Sensors



### **A reliable sensor for high conductivity sanitary applications**

Rosemount 225 toroidal conductivity sensors are intended to be used in many pharmaceutical and food and beverage applications where a sanitary design is required. These corrosion and fouling resistant sensors are ideal for measuring the concentration of CIP solutions, detecting product/water interfaces, checking product quality, and monitoring elements in chromatographic solutions.

# Overview

Rosemount 225 sensors are reliable sensors for high conductivity sanitary applications.

Rosemount 225 Toroidal Conductivity Sensors are intended to be used in many pharmaceutical and food and beverage applications where a sanitary design is required. These corrosion and fouling resistant sensors are ideal for measuring the concentrations of CIP solutions, detecting product/water interfaces, checking product quality, and monitoring eluents in chromatographic separations.



**Meet various sanitary requirements.**

- USP Class VI compliant.
- FDA food contact 21CFR177.2415 compliant.
- 3-A Sanitary Standard 74-06 compliant.

**Ease of installation.**

- 2-in. tri-clamp process connection.
- Installation flexibility with maximum cable lengths up to 200 ft. (61 m) (up to 100 ft. [30 m] is standard) between sensor and transmitter when paired with remote junction box (sold separately).

**High performance and reliability.**

- Robust measurements - insensitive to process flow and direction.
- Meet application compatibility requirements with a selection of chemical resistant body options including PEEK and Tefzel®.

---

**Contents**

Overview..... 2

Ordering information..... 3

Specifications..... 4

Dimensional drawing..... 5

Accessories..... 5

Engineering specifications..... 6

## Ordering information



Rosemount 225 Sanitary Toroidal Conductivity Sensors work well in high conductivity liquids up to 2 S/cm (2,000,000  $\mu$ S/cm). These sensors include an integral Pt-100 resistance temperature device (RTD) for temperature compensation and 20 ft. (6.1 m) of integral cable. Cables can be extended using a remote junction box PN 23550-00 (see [Accessories](#)).

**Table 1: Rosemount 225 Sanitary Toroidal Conductivity Sensor Ordering Information**

Option	Description
225	Toroidal Conductivity Sensor
<b>Body material and mounting type</b>	
03	Glass-filled PEEK with tri-clamp
07	Unfilled PEEK with tri-clamp
08	USP Class VI unfilled PEEK with tri-clamp <sup>(1)</sup>
09	Unfilled Tefzel <sup>(1)</sup>
<b>Transmitter compatibility</b>	
50	For use with Rosemount 1181T
54	For use with Rosemount series 1054 and 2054
56	Integral cable with additional shielding for improved EMI/RFI protection <sup>(2)</sup>
<b>Additional cable options - 20 ft. (6.1 m) is standard.</b>	
01	Integral 25-ft. (7.6 m) cable
35	Integral 35-ft. (10 m) cable
04	Integral 50-ft. (15 m) cable
06	Integral 100-ft. (30 m) cable
09	Integral 10-ft. (3 m) cable
<b>Calibration and conformance certificates - optional level</b>	
CC	Certificate of Calibration (no test data given)
LC	Loop Calibration Certificate (sensor and transmitter calibrated together, with test data)
EC	Electronic Calibration Certificate (sensor calibrated against factory instrument (with test data)
<b>Material traceability certificates - optional level</b>	
MC	Material Traceability Certification

(1) Only available with -56 option

(2) Recommended for use with Rosemount transmitter models 56, 1056, 5081, and 1066.

**Note**

The Rosemount 225 with 2-in. tri-clamp fitting is molded from unfilled or glass-filled PEEK. The sensor has an integral Pt 100 resistance temperature device (RTD) and 20 ft. (6,1 m) of cable. For improved EMI/RFI shielding, choose cable option 56. Option 07 meets 3-A sanitary standards.

## Specifications

Cell constant (nominal): 2.7/cm

Minimum conductivity: 200 μS/cm (15 μS/cm when used with Rosemount 1056 and 56 transmitters)

Maximum conductivity: 2 S/cm

Process connection: 2-in. tri-clamp

Conformance to 3-A sanitary standards: Sensors with option -07 meet 3-A sanitary standards for sensors and sensor fittings and connections used on milk and milk products equipment (74-06).

Compliance with FDA food contact requirements: Sensors with option -07 are molded from PEEK that meet 21CFR177.2415.

Compliance with USP Class VI: Sensors with option -08 are molded from PEEK that meet USP Class VI requirements

Standard cable length: 20 ft. (6.1 m)

Maximum cable length: 200 ft. (61 m), up to 100 ft. (30 m) is standard.

Weight/shipping weight: 2 lb./3 lb. (1.0 kg/1.5 kg)

**Table 2: Maximum Temperature and Pressure**

Body material option	Wetted materials	Maximum temperature	Maximum pressure
03	Glass-filled PEEK	230 °F (110 °C)	200 psig (1480 kpa[abs])
07	Unfilled PEEK (meets 21CFR177.2415 and 3A standard 74-06))	266 °F (130 °C)	
08	Unfilled PEEK (meets USP Class VI standards)		
09	Unfilled Tefzel	230 °F (110 °C)	

# Dimensional drawing

Figure 1: Rosemount 225 Dimensional Drawing

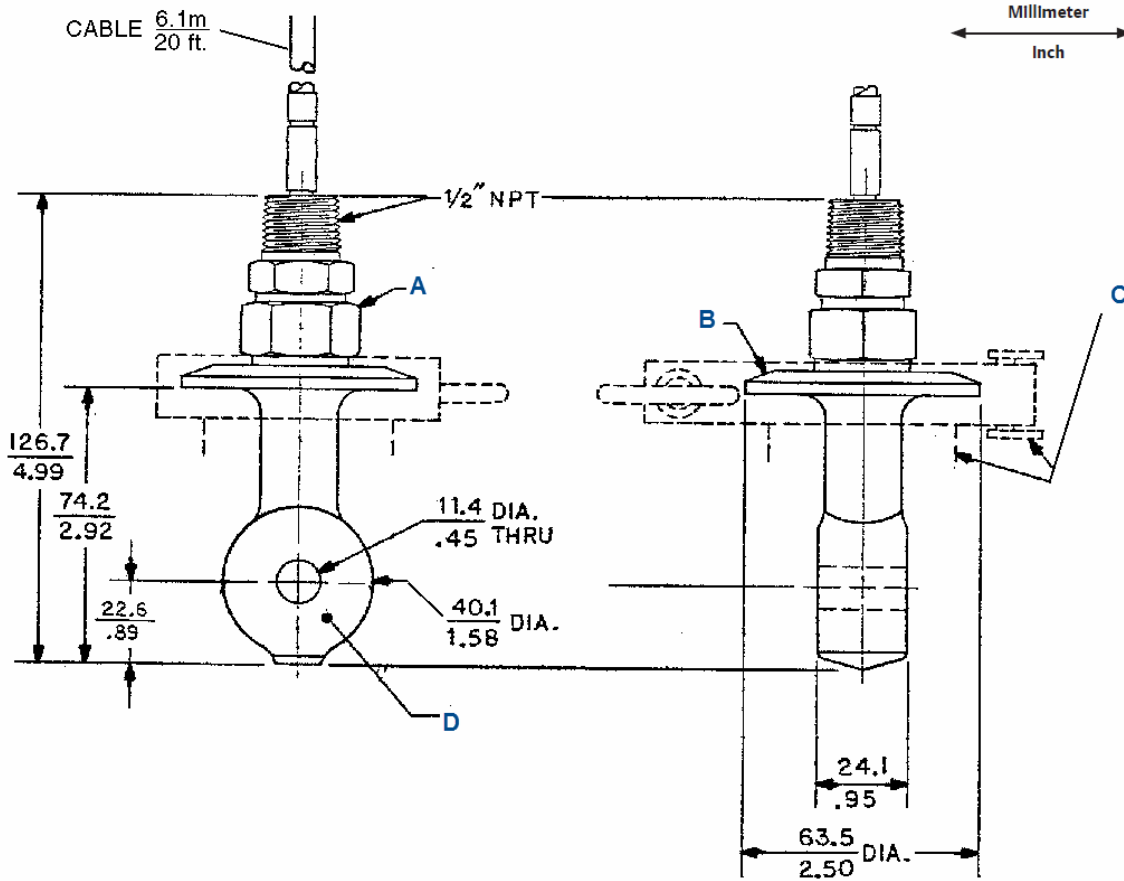

- A. Male connector 316 stainless steel
- B. Cap 316 stainless steel
- C. Clamp tee and gasket (supplied by others)
- D. Molded housing

## Accessories

Part number	Description
23550-00	Remote junction box without preamplifier
23294-00	Unshielded interconnecting cable for Rosemount 1054A, 1054B, and 2054C. Can also be used with Rosemount 1056, 56, 5081, and 1066-T, but not recommended. Prepped, specify length, per ft.
23294-05	Shielded interconnecting cable with additional shield wire for -03 option. For use with Rosemount 1056, 1066-T, 56, and 5081T. Prepped, specify length, per ft.
9200276	Extension cable, unprepped (specify length) per foot

## Engineering specifications

1. The sensor shall measure electrolytic conductivity using the inductive or toroidal method.
2. The sensor shall have a large bore to reduce fouling from fibrous materials in the process stream.
3. The sensor shall be molded from glass-filled PEEK, unfilled PEEK, or unfilled Tefzel® and have a 2-inch tri-clamp fitting.
4. The unfilled PEEK sensor shall be available in a version that meets 3A sanitary standard 74-06 and 21CFR177.2415.
5. The unfilled PEEK sensor shall also be available in an option that is molded from USP Class VI material.
6. The glass-filled PEEK and unfilled Tefzel sensor shall withstand 230 °F (110 °C) at 200 psig (1480 kPa abs).
7. The unfilled PEEK sensors shall withstand 266 °F (130 °C) at 200 psig (1480 kPa abs).
8. The sensor shall be Rosemount Model 225 or approved equal.



#### GLOBAL HEADQUARTERS

Emerson Automation Solutions  
6021 Innovation Blvd  
Shakopee, MN 55379, USA

📞 +1 800 999 9307 or +1 952 906 8888

📠 F +1 952 949 7001

✉️ liquid.csc@emerson.com

#### NORTH AMERICA

Emerson Automation Solutions  
8200 Market Blvd  
Chanhassen, MN 55317

📞 Toll Free +1 800 999 9307

📠 F +1 952 949 7001

✉️ liquid.csc@emerson.com

#### EUROPE

Emerson Automation Solutions  
Neuhofstrasse 19a P.O. Box 1046  
CH-6340 Baar  
Switzerland

📞 T + 41 (0) 41 768 6111

📠 F + 41 (0) 41 768 6300

✉️ liquid.csc@emerson.com

#### MIDDLE EAST AND AFRICA

Emerson Automation Solutions  
Emerson FZE  
Jebel Ali Free Zone  
Dubai, United Arab Emirates, P.O. Box 17033

📞 T +971 4 811 8100

📠 F +971 4 886 5465

✉️ liquid.csc@emerson.com

#### ASIA-PACIFIC

Emerson Automation Solutions  
1 Pandan Crescent  
Singapore 128461  
Singapore

📞 T +65 777 8211

📠 F +65 777 0947

✉️ liquid.csc@emerson.com

 [Linkedin.com/company/Emerson-Automation-Solutions](https://www.linkedin.com/company/Emerson-Automation-Solutions)

 [twitter.com/rosemount\\_news](https://twitter.com/rosemount_news)

 [Facebook.com/Rosemount](https://www.facebook.com/Rosemount)

 [youtube.com/RosemountMeasurement](https://www.youtube.com/RosemountMeasurement)

©2019 Emerson. All rights reserved.

The Emerson logo is a trademark and service mark of Emerson Electric Co. Rosemount is a mark of one of the Emerson family of companies. All other marks are the property of their respective owners.